

PLEXUS[®]

Bonding Solutions for Transport



TW



Working With You

Would you like to reduce your assembly costs, increase productivity and improve the quality of the finished component? The answer could be in your structural adhesive.

Plexus adhesive solutions have helped manufacturers in the bus, rail and truck industries to maintain and exceed existing standards in the transportation industry.

Suitable for bonding the vast majority of thermoplastics, metals and composite materials, Plexus ensures durable bonds, offering countless possibilities for design engineers and the production managers. By chemically fusing **plastics and composites**, Plexus ensures bonds so strong **the adhesive will outperform the substrate. In metal bonding Plexus adds value in applications where the aesthetic appearance is important and bond strength is crucial.**

Plexus structural adhesives can help reduce assembly costs in the transportation industry by:

- Minimizing or eliminating the need for surface preparation
- Curing at room temperature
- Simplifying assembly processes and shortening the assembly time
- Guaranteeing excellent fatigue and impact resistance

In addition to the improved design freedom and reliability, working with Plexus ensures you receive the fully comprehensive technical support and outstanding customer service expected from a leading global company.

The importance we place on building strong and lasting relationships with our customers, we believe, is a large part of our continuing success. We work in close collaboration with our customers, striving to understand all aspects of their bonding requirements and strive to meet their exacting specifications.

BROCHURE CONTENTS

- 4 Plexus for Trucks
- 8 Plexus for Buses
- 12 Plexus for Trains
- 16 Product Range
- 17 Dispensing Systems
- 18 European Technical Centre
- 18 Structural Adhesive Testing

QUALITY YOU CAN RELY ON

Our unrivaled commitment to quality is delivered in every adhesive we manufacture, providing our customers with confidence in the reliability of our products.

- Test programs and comprehensive support to aid design and production on customers own substrates
- Customer programs to establish actual environmental and in-service performance
- Invaluable technical and sales support, with additional guidance in product selection, joint design, application methods and equipment support
- Access to the global distribution network via strategic partners

To receive a more detailed overview of how Plexus could help. Please contact us at customerservice.shannon@itwpp.com.

Plexus Bonding Solutions Trucks

Worldwide, carbon emission standards are becoming more stringent and are an increasing challenge to truck manufacturers. Using Plexus adhesives can help reduce the overall weight of the vehicle and subsequently decrease emissions.

Working in partnership with design and engineering teams, Plexus aims to continually devise and implement new structural adhesive solutions and methods. Plexus specialists can be involved in the process from the original design stage to ensure a seamless transition to a bonded solution.

Plexus adhesive solutions have proven superior bonding performance, coupled with cost efficiency in the manufacturing process. This can be applied to a wide range of truck bonding applications to ensure durability and reliability with minimal disruption.

Our methyl methacrylate adhesives are a superior and practical alternative to traditional truck manufacturing methods and are approved by many Heavy Truck Manufacturers worldwide, including Peterbilt & Kenworth. The solutions are ideal for high liability truck assemblies, such as exterior trailer cappings, bumper assemblies, door extensions and exterior sun visors.

PRODUCT BENEFITS INCLUDE:

- UV stable
- Reduced VOC emissions
- High strength and durability
- Excellent resistance to salt spray
- Ease of use, no specialized training required
- Resistance to fuel, screen wash and other commonly used chemicals

BENEFITS OF BONDING WITH PLEXUS:

- Improved aesthetics and aerodynamic efficiency
- More design options due to the ability to bond dissimilar metals and materials
- A wide range of open and fixture times available to suit all applications
- Bondlines designed to withstand climatic stresses and different environmental conditions
- Easier recycling: no need to cut out the joint and is fully regrind compatible
- Avoid corrosion: no need to drill or pierce substrates for mechanical fastening.
- Reduction in the final weight of the assembly
- Improved efficiency and reduced emissions
- No need for mechanical fasteners



Plexus Bonding Solutions - Trucks

The truck illustration highlights where Plexus adhesives are used to bond many different substrates with little or no surface preparation.

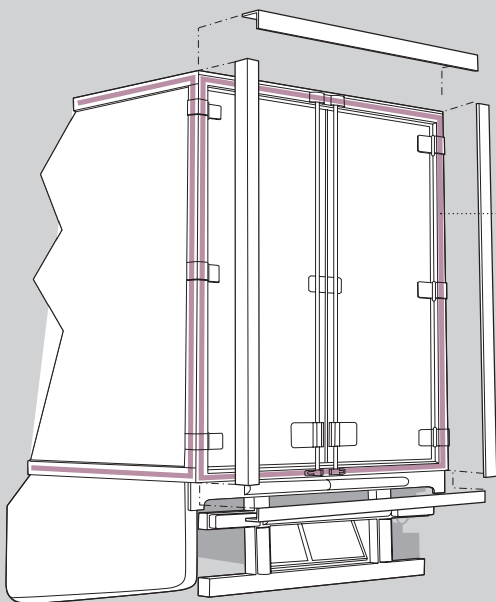

TRAILER CAPPING

Aluminium to composite bond to improve aesthetics.

BRACKETS

Structurally bonded throughout the vehicle to facilitate ease of installation.

ROOF SPOILER

Strong and durable bond of the composite wind deflector.

TRAILER ROOF

Dissimilar metals bonded to provide a high strength and corrosion free joint.

TRAILER LOAD LOCKERS

Metal rails bonded to trailer side walls to improve durability by evenly distributing load.

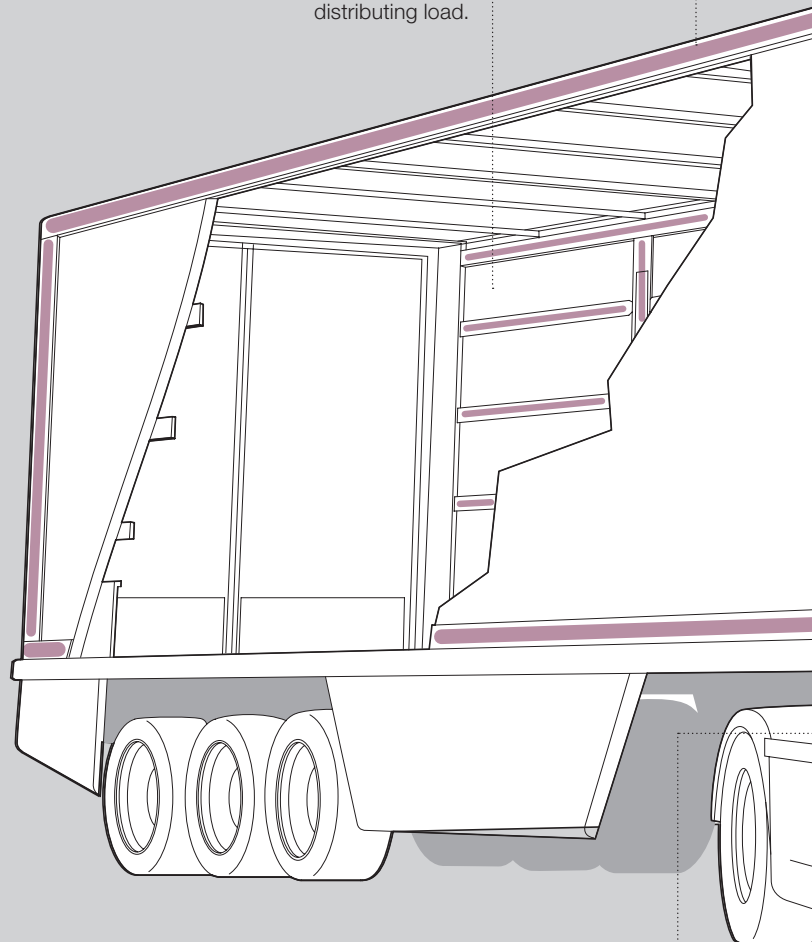

DOOR EXTENSION

Composite to metal bond improves process speed.

CABIN HOOD REINFORCEMENTS

Composite grid section bonded to composite shell to provide structural integrity.

SUN VISOR

Acrylic sheet bonded to mounting brackets offering excellent UV resistance, whilst improving production speed.

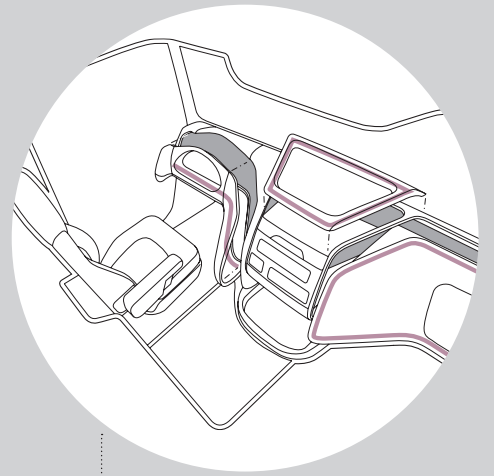

CABIN AND DASHBOARD

Brackets and stiffeners bonded in to aid installation.

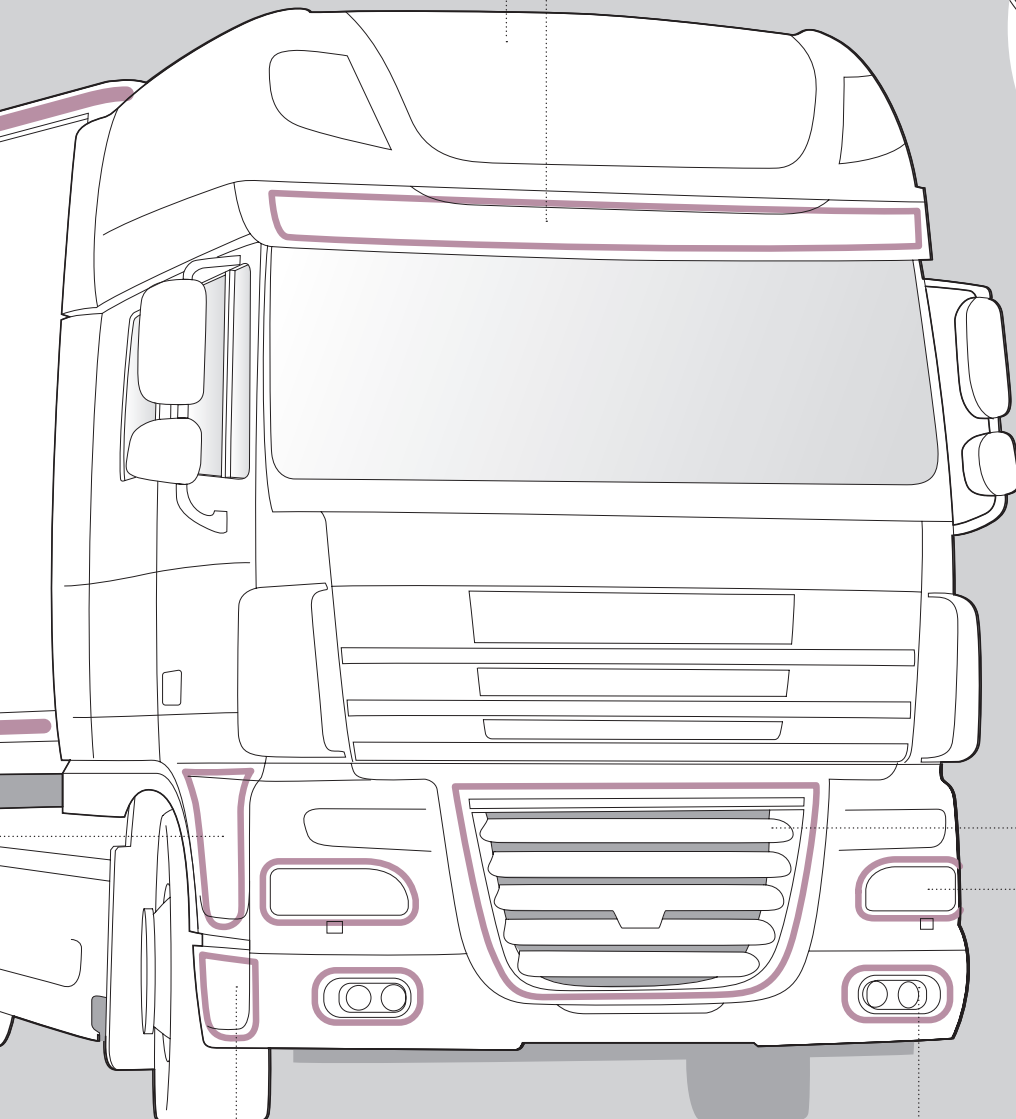

BUMPER END CAPS

Composite bonded to metal aiding durability and process speed.

FRONT FOG LIGHTS

Structurally bonded surrounds.

FRONT GRILL

Bond provides vibration housing and improved aesthetics.

HEADLIGHT SURROUND

Structurally bonded to provide secure lamp housing.



Plexus Bonding Solutions

Buses

Manufacturers of double-deckers, single-deckers and mini-buses are required to cope with a large number of daily commuters, ensuring they retain their durability and reliability over the typical 10-15 year life span.

We work closely with bus manufacturers to provide reliable fixtures for all challenging applications, including high liability assemblies such as front and rear end caps, internal mouldings and dashboard assemblies.

Plexus structural adhesives offer high strength with minimal surface preparation, therefore streamlining the production process. The unique characteristics of our adhesive systems allow bus manufacturers to replace welding structures, reduce distortion and post weld dressing and improve fatigue performance.

Plexus provides customers confidence in the strength and reliability of our adhesives. In addition, Plexus has contributed to the development and manufacture of low carbon buses, as bonding with GRP has allowed manufacturers to reduce weight and improve fuel efficiency.

PRODUCT BENEFITS INCLUDE:

- High structural strength
- High impact resistance
- Reduced VOC emissions
- Excellent fatigue resistance
- Easy to use, no specialized training required

BENEFITS OF BONDING WITH PLEXUS:

- Improved production speed by efficient processing and quick cure
- Improved aesthetics of the finished vehicle
- Wide range of open and fixture times available to suit all applications
- More design options and substrate choice: ability to bond dissimilar metals and materials
- Bondlines designed to withstand climatic stresses and different environmental conditions
- Lower component costs, due to the ability of adhesives to bond to a wide variety of different substrates
- No need for rivets, therefore significantly reducing individual stress points and the evenly distributing the load
- Avoid corrosion: no need to drill or pierce substrates for mechanical fastening

Plexus Bonding Solutions - Buses

The bus illustration demonstrates where Plexus adhesives can be applied. The bonding solutions are easy to use and fast fixture times meet production and process requirements.

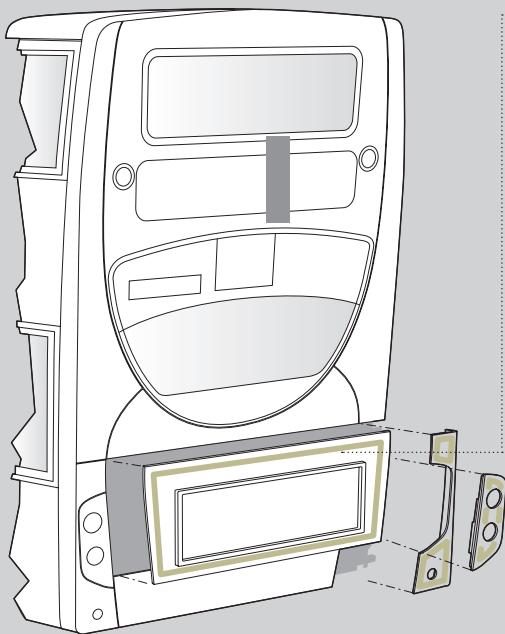

ENGINE COVER

Aluminium skin bonded to the frame, providing cost effective manufacturing and component strength.

BRACKETS

Structurally bonded throughout the vehicle to facilitate ease of installation.

WASHROOM ASSEMBLY

Bonded panels provide high performance water tight joints.

LOCKER DOORS

Aluminium skin bonded to the frame, providing cost effective manufacturing and component strength.

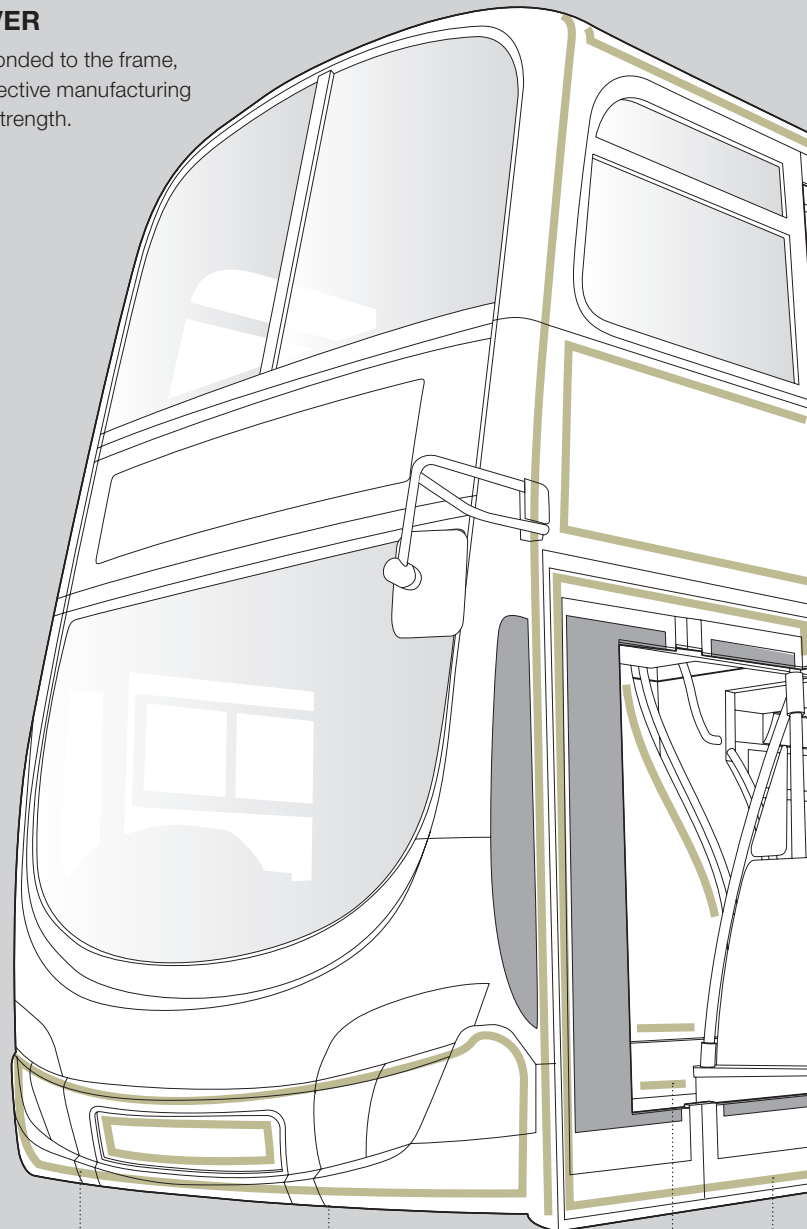

BUMPER

Mounting brackets structurally bonded to allow quick assembly.

STAIRWELL MOULD

Stiffeners and mounting brackets structurally bonded to provide strength and ease of installation.

ROOF COVING

Stiffeners and mounting brackets structurally bonded to provide strength and ease of installation.

ROOF TO EDGE FRAME

Bonds and seals metal to metal saving time and labour providing a durable watertight joint.

ROOF STRINGERS

Top hat stiffeners bonded into the roof to aid strength and lightness of the assembly.

SIDE PANEL (EXTERIOR SKIN)

Metal to metal bond designed to increase production speed and improve aesthetics.

REAR AND FRONT END CAP

Mounting brackets bonded to the mould for ease of installation.

RUB RAIL

Plastic to metal bond for durability.

WHEEL ARCHES

Aluminium skin bonded to the frame, providing cost effective manufacturing and component strength.

DOOR RUBBER SEAL

Rubber to metal bond provides weather resistance.

FLOOR PANELS

Structurally bonded panels provide high levels of resistance to heavy foot traffic.

DASHBOARD

Brackets and stiffeners bonded in to aid installation.

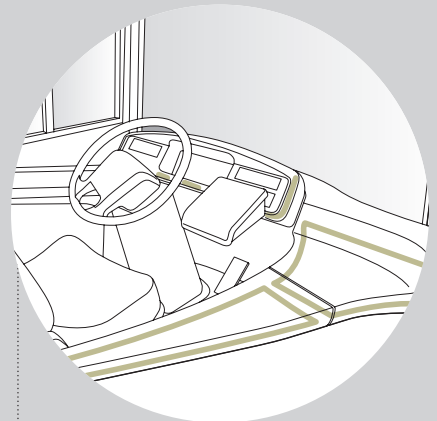

Plexus Bonding Solutions Trains

Durable bonded components are especially important when dealing with large numbers of daily commuters and travellers. At the forefront of innovative design, trains and carriages need to offer reliability, safety and optimal operational performance.

When using Plexus adhesives, manufacturers can assemble sub-components quickly and efficiently and apply modular assembly methods to production. Removing the need for mechanical fasteners can provide manufacturers with lower weight solutions.

Plexus adhesives have the ability to bond different types of plastics, metals and composites, helping to lower component costs, which is invaluable to the rail industry.

Plexus adhesives are used frequently during design and assembly to ensure these components remain intact and resistant to environmental stresses. Our unique adhesives offer distinct advantages when dealing with complex components and large surface areas.

Plexus adhesives MA300, MA310, MA420, MA515 and MA832 comply with R1 requirements for Hazard Levels HL1 – HL3 across all design and operational categories of rail vehicles.

R1/ Part 2 of EN45545-2:2013 standard for

- Toxicity – EN45545 Annex C (ISO 5659)
- Flammability (ISO 5658-2)
- Heat Release (ISO 5660-2)

PRODUCT BENEFITS INCLUDE:

- UV stable
- Reduced VOC emissions
- High strength and durability
- Excellent resistance to salt spray
- Ease of use, no specialized training required
- Resistance to fuel, screen wash and other commonly used chemicals

BENEFITS OF BONDING WITH PLEXUS:

- Improved aesthetics and aerodynamic efficiency
- More design options due to the ability to bond dissimilar metals and materials
- A wide range of open and fixture times available to suit all applications
- Bondlines designed to withstand climatic stresses and different environmental conditions
- Easier recycling: no need to cut out the joint and is fully regrind compatible
- Avoid corrosion: no need to drill or pierce substrates for mechanical fastening.
- Reduction in the final weight of the assembly
- Improved efficiency and reduced emissions
- No need for mechanical fasteners



Plexus Bonding Solutions - Trains

The illustration demonstrates the key joining areas where Plexus adhesives are applied. Our adhesive solutions are suitable for bonding a wide range of substrates including metals, coated steel and plastics.

LITTER BIN

Composite assembly bonded for strength.

PASSENGER DISPLAY

Protective cover bonded into composite moulding.

HEADLIGHT COVER

Structurally bonded to improve aesthetics and durability.

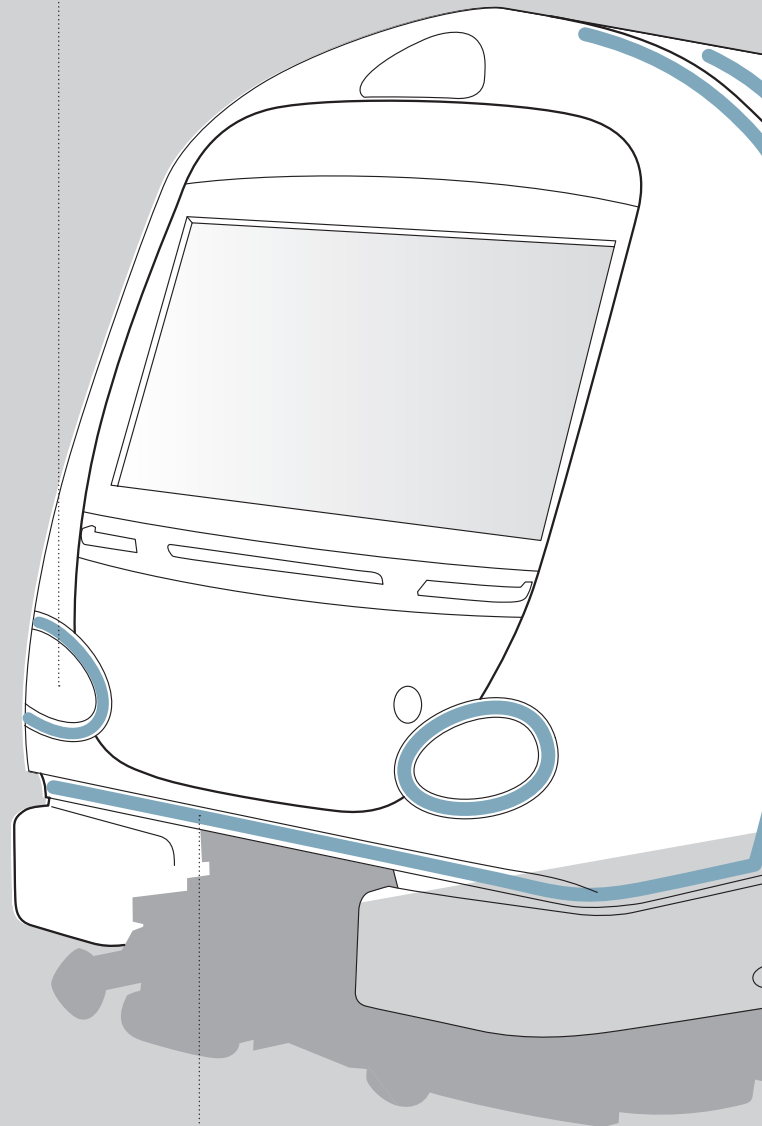
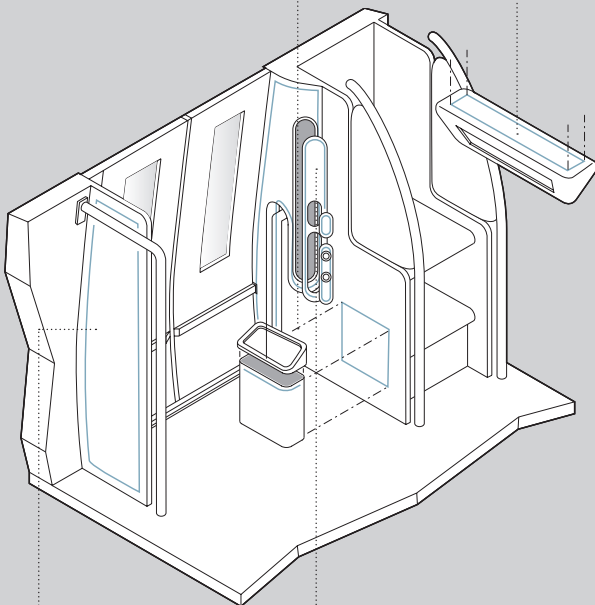

DRAUGHT SCREEN AND STANDBACK

Brackets and stiffeners bonded into composite panel to aid aesthetics and ease of installation.

CAB MOULDING

Mounting brackets bonded to the moulding for ease of installation.

ROOF FAIRING

Structurally bonded to aid aerodynamic performance.

WINDOWS

Stiffening beams bonded to composite moulding to improve structural strength.

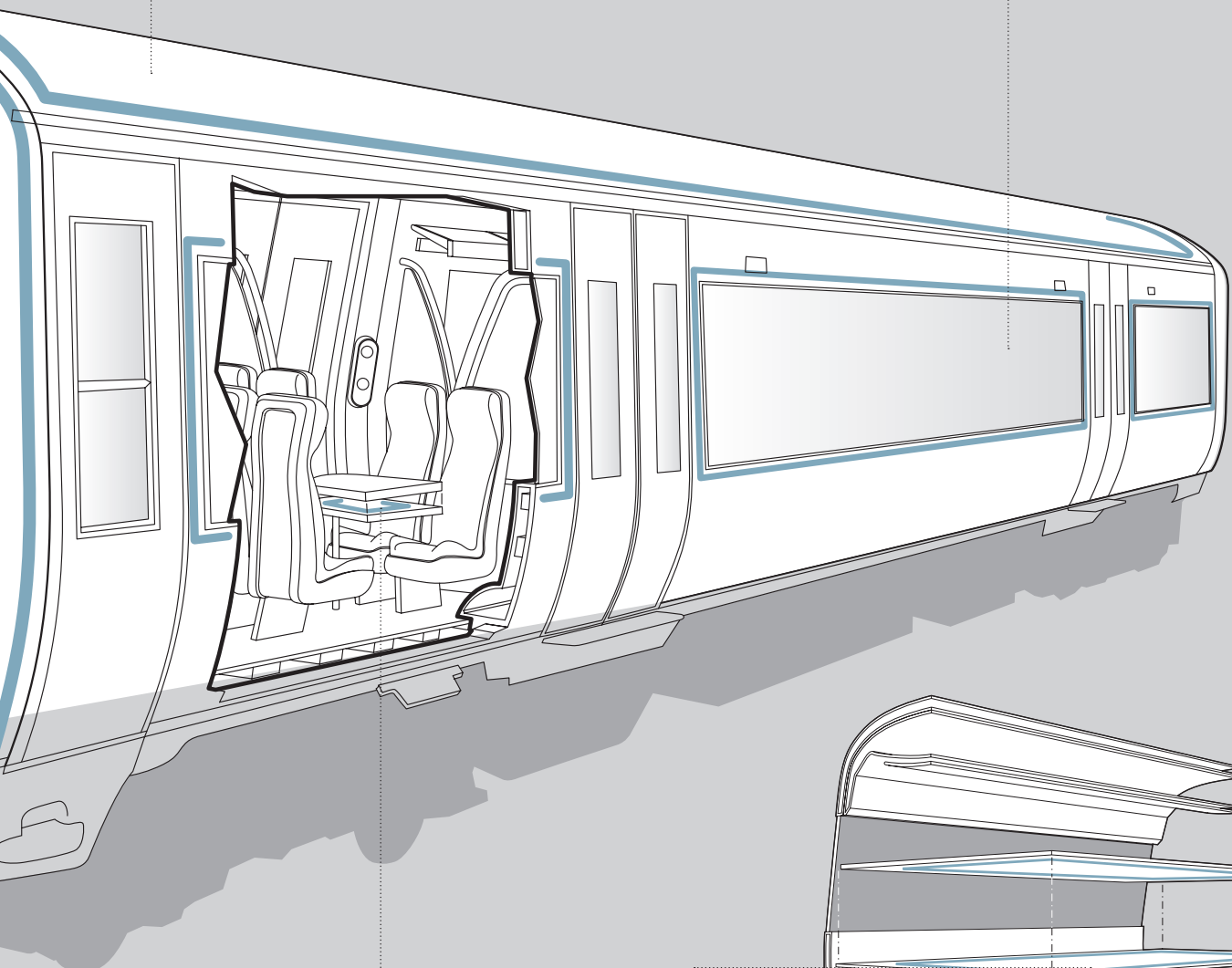

TABLES

Composite panels bonded together improves process speed.

FLOOR

Composite panels bonded to aluminium framework to provide strength and durability.

Products

Methacrylate structural adhesives are now commonplace in highspeed production processes, and offer engineers a range of benefits from joint design to manufacturing efficiency savings.

To select the most suitable structural adhesive, we recommend our customers consider the following factors:

- Design parameters
- Substrates used
- Production environment
- Bond strength requirements

Plexus recommends the following adhesive ranges for use in transportation applications:

300 SERIES

Includes both 1:1 and 10:1 general purpose adhesives

Main benefits:

- High adhesion
- Excellent impact resistance
- Little or no surface preparation
- Good environmental durability
- Aesthetic finish to the component
- High shear strengths up to 24 MPa

Ideal for bonding:

- GRP's
- Metals
- Phenolics
- Most plastics
- Nylon and gelcoats

400 SERIES

A multipurpose range of 10:1 adhesives

Main benefits:

- Excellent elongation
- High chemical and impact resistance
- Wide range of open and working times to suit specific applications
- Little or no surface preparation
- High shear strength
- Tough and durable bonds

Ideal for bonding:

- Large components which require a longer working and fixture time

800 SERIES

"Metal Bonding" series of fast curing, structural adhesives

Main benefits:

- Strong yet flexible
- Excellent adhesions
- No need for primers
- No need for extensive surface preparation
- Allow users to move away from traditional methods such as mechanical fastenings, riveting, welding

Ideal for bonding:

- Variety of ferrous and non-ferrous metals including aluminum, stainless steel and carbon steel



Metering Mixing and Dispensing Machines

Specifically developed to process high viscosity material systems, the metering, mixing and dispensing machine, is recognised as the industry standard for dispensing precise doses or accurate beads of mixed product within a wide range of applications.

Suitable for processing the majority of two-part, high viscosity material systems, these proven metering and mixing systems, provide a clean and cost efficient alternative to hand mixing.

FEATURES AND BENEFITS OF PLEXUS DISPENSING MACHINES

- **Metering Pumps:** Single acting positive displacement.
- **Ratio Range:** Fixed ratios are available from 1:1 to 13:1.
- **Viscosity acceptance:** Up to 1,000,000 + cps.
- **Shot size:** 15ml to 100ml at a ratio of 10:1.
- **Cycle rate:** Up to 20 shots per minute.
- **Mixing:** Disposable Static or Base Purge Static.
- **Reservoir Capacity:** 18 litre or pump fed from 20 litre pails.
- **Controls:** Air supply filter regulator and gauge, machine on/off, dispense pressure regulator and gauge, foot valve start and emergency stop.
- **Services:** Clean, dry compressed air @ 80 psi.
- Suitable for processing the majority of two-part, high viscosity material systems.
- Provides a clean and cost efficient alternative to hand mixing.
- Eliminates the requirement for solvent cleaning.

The Plexus technical support team has decades of research knowledge and practical experience dealing with the specific requirements of our customers. We can provide Installation, commissioning and onsite training to our customers.

The Plexus team works closely with leading equipment manufacturers to ensure that their own full range of machines are also manufactured to suit our adhesives. These machines range from industry standard piston pump machines through to complete “closed loop” systems to suit the requirements of high volume robotic applications that some of our customers require.

ANCILLARY EQUIPMENT

Plexus equipment range also includes manual and pneumatic dispense guns to suit both 1:1 and 10:1 cartridges, specifically for dispensing our adhesives, and a range of static mixers to suit most applications.



Structural Adhesive Testing

Although structural adhesives have revolutionised manufacturing and assembly industries, the technology is still in its relative infancy in comparison to traditional methods of joining substrates.

Our challenge is to demonstrate that structural adhesives will outperform traditional methods in terms of improved aesthetics, durability, and fatigue resistance.

At Plexus we have a specific test program allowing us to test the type and level of stress the joint will experience over its service life.

Tests simulate the vibrations, harmonics and repeated cyclic loading together with the chemical and environmental exposures in transportation assemblies.

Using a representative sample of the substrates, and correlating the number of cycles with the service conditions, can assist in predicting the number of days, months or years until failure.

Our static and dynamic testing offers valuable data to the designer of two component assemblies and insures long-term part performance.

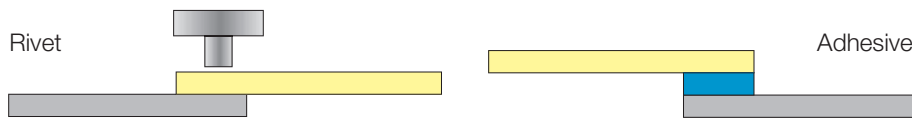

	Lap Shear Strength	Failure Mode
Rivet Joint	1.77 MPa	Rivet Failure
Plexus Adhesive Joint	4.17 MPa	Substrate Failure

% of Ultimate Strength	Number of cycles to Failure RIVET*	Number of cycles to Failure ADHESIVE**
100	1	800,000
90	3,684	832,670
80	11,532	1,125,000

*Rivet Failure **Substrate Failure

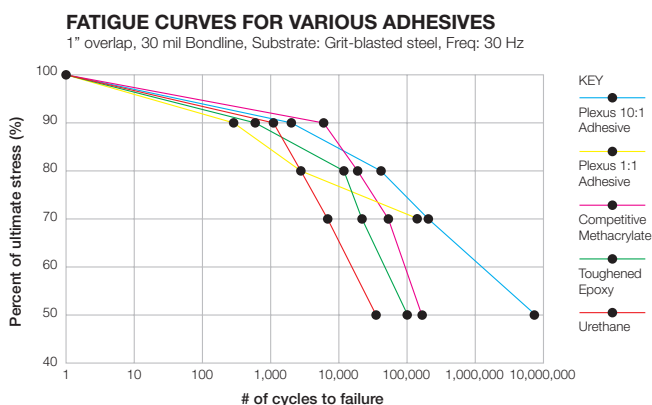

Not only does the adhesive joint provide a stronger bond than the rivet, but when tested in fatigue, Plexus adhesives outperform the riveted joint by over 98%.

Fatigue resistance is important when a bonded joint is likely to be exposed to vibration, shock and impact. Plexus methacrylates can outperform other adhesive technologies and systems as seen in the chart opposite.

European Technical Centre

The Plexus European Technical Centre offers our customers a facility that delivers comprehensive and technically proven solutions.

Within the fully equipped laboratory we have the ability to carry out tensile, impact, fatigue, thermal, climatic and environmental testing on a variety of substrates. Combining our extensive database of materials and applications with our in-house experts, we use predictive testing to simulate the environmental effects on the manufacturing process.

All testing and subsequent adhesive selection is therefore adapted to each customer's individual needs to provide the professional advice your business needs.

TESTING METHODOLOGY

Samples of each joining method are first tested as static lap shears which were pulled to failure at a constant speed. The average maximum stress is referred to as the ultimate strength which represents the load that the joint can bear in a single cycle. Samples are cyclically fatigue tested to various percentages of their ultimate strength. Cycles are performed at a rate of 30 cycles per second (30 Hz).



ITW Performance Polymers

North America

30 Endicott Street
Danvers
MA 01923
T. +1 978-777-1100
F. (978) 774-0516
E: cs@itwpp.com
www.itwpp.com

ITW Performance Polymers

North America

130 Commerce Drive
Montgomeryville, PA 18936
T: 215-855-8450
E: customerservice.na@itwpp.com
www.itwpp.com

ITW Performance Polymers

Europe

Bay 150
Shannon Industrial Estate
Shannon, County Clare
Ireland
T. +353 61 771 500
E: customerservice.shannon@itwpp.com
www.itwpp.com

ITW Performance Polymers

Europe

Rordalsvej 44
9220 Aalborg
Denmark
T: +45 9816 7011
E: customerservice.aalborg@itwpp.com
www.itwpp.com

ITW Polymers Asia

10,27F, Xingyuan Building
No. 418, Guiping Rd.
Cao He Jing Hi-Tech Park
Shanghai
China 200233
T. 021-54261212
www.itwppchina.com

30-32 Enoki-cho,
Suita, Osaka 564-0053
Japan
T. +81-6-6330-7118
www.itwppjapan.com

13th floor, PAX Tower, Unit B
231-13, Nonhyeon-Dong, Gangnam-Gu
Seoul, Korea 135-010
T. +82-2-2088-3560
www.itwppkorea.com

ITW PP&F

Brazil

Rua Antonio Felamingo, 430
Macuco, Valinhos, SP 13279-452
T: +55 19 2138-7600
www.itwppf.com.br

PLEXUS[®]
www.itwperformancepolymers.com

